



EUROPA REFERENCE BOOKS
for Automotive Technology

Modern Automotive Technology

Fundamentals, service, diagnostics

2nd English edition

The German edition was written by technical instructors, engineers and technicians

Editorial office (German edition): R. Gscheidle, Studiendirektor, Winnenden – Stuttgart

VERLAG EUROPA-LEHRMITTEL · Nourney, Vollmer GmbH & Co. KG
Düsseldorf Straße 23 · 42781 Haan-Gruiten, Germany

Europa-No.: 23018

Modern Automotive Technology - Fundamentals, service, diagnostics, 2nd edition 2014
Original title: Fachkunde Kraftfahrzeugtechnik, 30th edition 2013

Authors:

Fischer, Richard	Studiendirektor	Polling – Munich
Gscheidle, Rolf	Studiendirektor	Winnenden – Stuttgart
Gscheidle, Tobias	Dipl.-Gwl., Studienrat	Stuttgart – Sindelfingen
Heider, Uwe	Kfz-Elektriker-Meister, Trainer Audi AG	Neckarsulm – Oedheim
Hohmann, Berthold	Studiendirektor	Eversberg – Meschede
van Huet, Achim	Dipl.-Ingenieur, Oberstudienrat	Oberhausen – Essen
Keil, Wolfgang	Oberstudiendirektor	Munich
Lohuis, Rainer	Dipl.-Ingenieur, Oberstudienrat	Hückelhoven – Cologne-Deutz
Mann, Jochen	Dipl.-Gwl., Studiendirektor	Schorndorf – Stuttgart
Schlögl, Bernd	Dipl.-Gwl., Studiendirektor	Rastatt – Gaggenau
Wimmer, Alois	Oberstudienrat	Stuttgart
Wormer, Günter	Dipl.-Ingenieur	Karlsruhe

Head of working group and editorial office:

Rolf Gscheidle, Studiendirektor, Winnenden – Stuttgart, Germany

Illustrations:

Drawing office of Verlag Europa-Lehrmittel, Ostfildern, Germany

All information given in this book corresponds to the state of the art. All testing, measuring and repair work on a specific vehicle must be carried out in accordance with the manufacturer's specifications. The work described is performed at the user's own risk. Warranty claims against the authors or the publisher are excluded.

2nd edition 2014

Impression 5

All impressions of the same edition can be used in parallel, as they do not differ from each other except with regard to the correction of printing errors.

ISBN 978-3-8085-2302-5

All rights reserved. This book is protected by copyright. Any commercial use beyond the legally specified uses requires written approval from the publisher.

© 2014 by Verlag Europa-Lehrmittel, Nourney, Vollmer GmbH & Co. KG, 42781 Haan-Gruiten, Germany
www.europa-lehrmittel.de

Cover design and illustration: braunwerbeagentur, Stefanie Braun, 42477 Radevormwald, Germany, using photographs and illustrations provided by Dr. Ing. H. C. Porsche AG, Stuttgart, Audi AG, Ingolstadt, Volkswagen AG, Wolfsburg, KTM, Mattighofen, Austria (photo: H. Mitterbauer) and Mercedes Benz AG, Stuttgart.

Translation and editing of the 2nd English edition:

Lynn E. Webb, Helena, MT, USA with assistance from Kevin J. Fulton, Ann Arbor, MI, USA

Typesetting: Satz+Layout Werkstatt Kluth GmbH, 50374 Erftstadt, Germany

Printing: Plump Druck & Medien GmbH, 53619 Rheinbreitbach, Germany

Foreword

"Modern Automotive Technology" is a standard work covering the subject of automotive technology. This second English edition is based on the 30th German edition titled "Fachkunde Kraftfahrzeugtechnik". It has for many years proven to be a highly popular textbook used for training and further education. It provides apprentices, trainees, teachers and all those interested in this subject with the theoretical knowledge necessary to gain a firm grasp of the practical and technical skills involved. Fundamental, technical connections between individual systems are presented in a clear and comprehensible way.

The book is intended to be used as a reference work by employees in the automotive industry and in motor vehicle service outlets, by teachers, apprentices, trainees and automotive technology students to help them look up information and supplement their technical knowledge. The work is intended to be used by all those interested in automotive technology as a means of extending their technical knowledge through private study.

The 22 chapters are logically arranged by subject and cover the changes that have occurred in the field of automotive technology. The book is particularly suitable for practical training in all matters pertaining to motor vehicles.

This work covers the latest developments in automotive technology, including service and maintenance of vehicle systems, management, communication, supercharging technology, common-rail systems, dual clutch gearboxes, electronic transmission control, electronic brake systems, compressed-air monitoring systems, adaptive cornering lights, new headlamp systems, high-frequency technology, electrical circuit diagrams, multifunction regulators, new data bus systems (LIN, MOST, FlexRay), alternative drive concepts, electric drive systems, differential locks, axle alignment checks, driving dynamics, steering systems, electromagnetic compatibility and comfort and convenience systems such as adaptive cruise control, parking assistance and navigation. A large chapter is devoted to the subject of electrical engineering. Here, the detailed coverage of the fundamentals of electrical engineering forms the basis for all the crucial issues and topics pertaining to automotive electrics, up to and including data transmission in motor vehicles. A separate chapter is devoted to the increasing importance in engineering of comfort and convenience technology.

Reference is made to German and European standards in the chapters on environmental protection and occupational safety, emissions-control engineering, braking technology and motorcycle engineering. However, compliance with the standards applicable in the respective individual countries is required.

The work features numerous coloured pictures, drawings and system diagrams as well as particularly clearly and comprehensibly laid-out tables. These will help the reader to digest and comprehend the complex subject matter.

The work has been written and compiled – in close co-operation with the automotive trade and industry – by a team of educationally experienced vocational school teachers, engineers and master tradesmen. The authors and the publishers will be grateful for any suggestions and constructive comments.

We would like to thank all the companies and organisations who have kindly contributed pictures and technical documents.

Abbreviations

AAS	Adaptive air suspension	CB	Centre bore, Common ball	EDP	Electronic data processing
A/C	Air conditioning	CBS	Combined brake system	EDTC	Engine drag torque control
A/F	Air/fuel (mixture)	CC	Cruise control	EEPROM	Electrically erasable programmable read-only memory
ABA	Active brake assist	CDI	Capacitive discharge ignition	EGR	Exhaust gas recirculation
ABC	Active body control	CFPP	Cold filter plugging point	EGS	Electronic gearbox control unit (German: Elektronisches Getriebesteuergerät)
ABS	Antilock braking system	CFRP	Carbon fibre reinforced plastic	EH	Extended hump
ABV	Automatic braking-force distribution (German: Automatische Bremskraftverteilung)	CH	Combination hump	EHB	Electro-hydraulic braking system
AC	Alternating current	CIH	Camshaft in head	EI	Emissions inspection, electronic ignition
ACC	Adaptive cruise control, automatic cruise control	CIP	Continuous improvement process	ELSD	Electronic limited-slip differential
ACEA	Association des Constructeurs Européens d'Automobiles	CN	Cetane number	EMC	Electromagnetic compatibility
ACS	Automatic clutch system	CNG	Compressed natural gas	EMS	Electronic engine management system
AD	Analogue digital (converter)	CPOD	Child Seat Presence and Orientation Detection	Eo	Exhaust valve opens
ADC	Analog digital converter	CPU	Central processing unit	EOBD	European on board diagnostics
ADSL	Asymmetrical digital subscriber line	CR	Common rail	EP	Exhaust passage, extreme pressure, epoxy resin
AFS	Airflow sensor	CRDI	Common rail direct injection	EPS	Electronic power steering
AFRP	Aramid fibre reinforced plastic	CB	Centre bore	ESI	Electronic service information
AGM	Absorbed glass mat battery	CS	Crankshaft	ESP	Electronic stability program
AHL	Automatic headlight leveling	CV	Commercial vehicle	ETC	Electronic throttle control
ALDBFR	Automatic load-dependent brake force regulator	CV	Check valve	ETN	European type number
ALSD	Automatic limited-slip differential	CVlft	Check valve left	EV	Exhaust valve
AM	Amplitude modulation	CVrt	Check valve right	FA	Front axle
API	American Petroleum Institute	CVT	Continuously variable transmission	FB	Function button
APB	Automatic parking brake	DA	Drive axle	FC	Fuel cell
ARS	Angle of rotation sensor	DC	Direct current	FF	Free-form (reflector)
ASC	Anti-stability control, acceleration skid control	DCT	Dual clutch transmission	FH	Flat hump
ASHEV	Axle split hybrid electric vehicle	DI	Direct injection	FL	Front left
ASTM	American Society for Testing and Materials	DIN	Deutsches Institut für Normung	FOC	Fibre optic cable
ATC	Adaptive transmission control	DIP	Distributor injection pump	FOT	Fibre optic transceiver
ATF	Automatic transmission fluid	DME	Digital motor electronics	FR	Front right
AWD	All-wheel drive	DOHC	Double overhead camshaft	GD/GND	Ground
AYC	Active yaw control	DOT	Department of Transportation	GDI	Gasoline direct injection
BAS	Brake assist system	DPNR	Diesel particulate NO _x reduction system	GFRP	Glass fibre reinforced
BDC	Bottom dead centre	DSC	Dynamic stability control	GI	General inspection
BDW	Brake disc wiping	DSG	Direct-shift gearbox	GPS	Global positioning system
BEV	Battery powered electric vehicle	DSP	Dynamic shift program selection	HDC	Hill descent control
CA	Crankshaft angle	DVD	Digital versatile disc	HEV	Hybrid electric vehicle
CS	Camshaft	EBA	Electronic brake assist, emergency brake system	HF	High frequency
CAN	Controller area network	EBS	Electronic braking system	HGV	Heavy goods vehicle
CAT	Catalytic converter, catalyst	Ec	Exhaust valve closes	HHC	Hill hold control
		ECE	Economic Commission for Europe	HNS	Homogeneous numerically calculated surface
		ECM	Electronic clutch management	HS	High-solid (paints)
		ECS	Electronic clutch system	HTHS	High temperature, high shear
		ECU	Electronic control unit, engine control unit	HUD	Head up display
		EDC	Electronic diesel control, electronic damper control		

Abbreviations

HV	Hybrid vehicle, high voltage	NEDC	New European driving cycle	SAE	Society of Automotive Engineers
IC	Integrated circuit	NF	Non-ferrous	SAM	Signal acquisition and actuation module
lc	Inlet valve closes	NIT	Network idle time	SBC	Sensotronic brake control
IC	Individual control	NLGI	National Lubricating Grease Institute	SC	Signal conditioning
IHPF	Internal high-pressure forming	NTC	Negative temperature coefficient	SCR	Selective catalytic reduction
lo	Inlet valve opens	OBD	On-board diagnostics	SCV	Solenoid control valve
IP	Inlet passage	OD	Outside diameter	SDC	Semi-drop centre
IPO	Input/Processing/Output (principle)	OHC	Overhead camshaft	SE	Sensor
IS	Input shaft	OHV	Overhead valves	SG	Strain gauge
ISA	Integrated starter alternator	ON	Octane number	SI	Safety inspection
ISAD	Integrated starter alternator damper	OV	Outlet valve	SL	Special ledge
ISC	Idle speed control	OVlft	Outlet valve left	SLC	Select-low control
ISG	Integrated starter generator	OVrt	Outlet valve right	SoC	State of charge
ISO	International Organization for Standardization	PBC	Parking brake circuit	SPI	Single-point injection
IV	Inlet valve	PC	Polycarbonate, personal computer	SRR	Short range radar
IVlft	Inlet valve left	PCD	Pitch circle diameter	SRS	Safety restraint systems, supplemental restraint system
IVrt	Inlet valve right	PEM	Proton exchange membrane	SSlft	Speed sensor left
LA	Lifting axle	PES	Poly ellipsoid system (reflector)	SSrt	Speed sensor right
LAN	Local area network	PHEV	Plug-in hybrid electric vehicle	STP	Shielded twisted pair
LDC	Liquid crystal display	PIN	Personal identification number	STVZO	Straßenverkehrs-zulassungsordnung (Germany)
LDR	Light-dependent resistor	PM	Particulate matter	SUV	Sport Utility Vehicle
LED	Light-emitting diode	POF	Plastic optical fibre	SV	Solenoid valve
LEV	Low-emission vehicle	POT	Plastic optical transceiver	SV	Side valve
LF	Low frequency	PS	Pressure sensor	SW	Short wave
LI	Load index	PTC	Positive temperature coefficient	SWR	Standing wave ratio
LIN	Local interconnect network	PWM	Pulse width modulation	Tc	Transfer passage closes
Li-ion	Lithium ion	QA	Quality assurance	TC	Turbocharger
LNG	Liquefied natural gas	QM	Quality management	TCS	Traction control system
LS	Limited slip	RA	Rear axle	TDC	Top dead centre
LSG	Laminated safety glass	RAM	Random access memory	TIG	Tungsten-inert gas
LU	Logical unit	RDS	Radio data system	TL	Tubeless
LV	Low voltage	RL	Rear left	TMC	Traffic message channel
LW	Long wave	RLFS	Return-less fuel system	To	Transfer passage opens
MAF	Mass air flow	RON	Research octane number	TP	Transfer passage
MAG	Metal active-gas (welding)	ROM	Read-only memory	TPC	Tyre pressure check, tyre pressure control
MC	Microcomputer	ROP	Rollover protection	TSG	Tempered safety glass
MC	Main cylinder	ROV	Rotating high voltage distribution (German: Rotierende Hochspannungsverteilung)	TÜV	German technical inspection association
ME	Motor electronics	RR	Rear right	TWI	Tread wear indicator
MED	Motor electronics direct injection	RRC	Radio remote control	UIS	Unit injector system
MG	Motor generator	RUV	Static high voltage distribution (German: Ruhende Hochspannungsverteilung)	UPS	Unit pump system
MIG	Metal inert-gas (welding)	SAC	Self-adjusting clutch	VDC	Vehicle dynamics controller
MIL	Malfunction indicator lamp			VDR	Voltage-dependent resistor
MODIC	Mobile diagnostic computer			VF	Variable focus (reflector)
MON	Motor octane number			VHF	Very high frequency
MOST	Media oriented systems			VI	Viscosity index
MPI	Multipoint injection			VT	Viscosity temperature
MS	Medium-solid (paints)			VTEC	Variable valve timing and lift electronic control
MW	Medium wave			VTG	Variable turbine geometry

We wish to thank the companies listed below for providing technical advice, information, photographs and illustrations.

- Alfa-Romeo Automobiles**
Milan, Italy
- ALLIGATOR Ventilfabrik GmbH**
Giengen/Brenz, Germany
- Aprilia Motorrad-Vertrieb**
Düsseldorf, Germany
- Aral AG**, Bochum, Germany
- Audatex Deutschland**, Minden, Germany
- Audi AG**, Ingolstadt – Neckarsulm, Germany
- Autokabel**, Hausen, Germany
- Autoliv**, Oberschleißheim, Germany
- G. Auwärter GmbH & Co**
(Neoplan) Stuttgart, Germany
- BBS Kraftfahrzeugtechnik AG**,
Schiltach, Germany
- BEHR GmbH & Co**, Stuttgart, Germany
- Beissbarth GmbH**, Automobil Service-
geräte, Munich, Germany
- BERU**, Ludwigsburg, Germany
- Aug. Bilstein GmbH & Co KG**
Ennepetal, Germany
- Boge GmbH**, Eitdorf/Sieg, Germany
- Robert Bosch GmbH**, Stuttgart, Germany
- Bostik GmbH**
Oberursel/Taunus, Germany
- BLACK HAWK**, Kehl, Germany
- BMW Bayerische Motoren-Werke AG**
Munich/Berlin, Germany
- CAR-OLINER**, Kungsör, Sweden
- CAR BENCH INTERNATIONAL S.P.A.**
Massa, Italy
- Continental Teves AG & Co, OHG**
Frankfurt, Germany
- Celette GmbH**, Kehl, Germany
- Citroen Deutschland AG**
Cologne, Germany
- Dataliner Richtsysteme**
Ahlerstedt, Germany
- Deutsche BP AG**, Hamburg, Germany
- DUNLOP GmbH & Co KG**
Hanau/Main, Germany
- ESSO AG**, Hamburg, Germany
- FAG Kugelfischer Georg Schäfer KG aA**
Ebern, Germany
- J. Eberspächer**, Esslingen, Germany
- EMM Motoren Service**, Lindau, Germany
- Ford-Werke AG**, Cologne, Germany
- Carl Freudenberg**
Weinheim/Bergstraße, Germany
- GKN Löbro**, Offenbach/Main, Germany
- Getrag Getriebe- und Zahnradfabrik**
Ludwigsburg, Germany
- Girling-Bremsen GmbH**
Koblenz, Germany
- Glasurit GmbH**
Münster/Westphalia, Germany
- Globaljig, Deutschland GmbH**
Cloppenburg, Germany
- Glyco-Metall-Werke B.V. & Co KG**
Wiesbaden/Schierstein, Germany
- Goetze AG**, Burscheid, Germany
- Grau-Bremse**, Heidelberg, Germany
- Gutmann Messtechnik GmbH**
Ihringen, Germany
- Hazet-Werk**, Hermann Zerver
Remscheid, Germany
- HAMEG GmbH**, Frankfurt/Main, Germany
- Hella KG, Hueck & Co**
Lippstadt, Germany
- Hengst Filterwerke**, Nienkamp, Germany
- Fritz Hintermayr**, Bing-Vergaser-Fabrik
Nuremberg, Germany
- HITACHI Sales Europa GmbH**
Düsseldorf, Germany
- HONDA DEUTSCHLAND GMBH**
Offenbach/Main, Germany
- Hunger Maschinenfabrik GmbH**
Munich and Kaufering, Germany
- IBM Deutschland**, Böblingen, Germany
- IVECO-Magirus AG**, Neu-Ulm, Germany
- ITT Automotive (ATE, VDO,**
MOTO-METER, SWF, KONI, Kienzle)
Frankfurt/Main, Germany
- IXION Maschinenfabrik**
Otto Häfner GmbH & Co
Hamburg-Wandsbeck, Germany
- Jurid-Werke**, Essen, Germany
- Alfred Kärcher GmbH & Co. KG**
Winnenden, Germany
- Kawasaki-Motoren GmbH**
Friedrichsdorf, Germany
- Knecht Filterwerke GmbH**
Stuttgart, Germany
- Knorr-Bremse GmbH**, Munich, Germany
- Kolbenschmidt AG**, Neckarsulm, Germany
- KS Gleitlager GmbH**
St. Leon-Rot, Germany
- KTM Sportmotorcycles AG**
Mattighofen, Austria
- Kühnle, Kopp und Kausch AG**
Frankenthal/Palatinate, Germany
- Lemmerz-Werke**, Königswinter, Germany
- LuK GmbH**, Bühl/Baden, Germany
- MAHLE GmbH**, Stuttgart, Germany
- Mannesmann Sachs AG**
Schweinfurt, Germany
- Mann und Hummel, Filterwerke**
Ludwigsburg, Germany
- MAN Maschinenfabrik**
Augsburg-Nürnberg AG
Munich, Germany
- Mazda Motors Deutschland GmbH**
Leverkusen, Germany
- MCC – Mikro Compact Car GmbH**
Böblingen, Germany
- Messer-Griesheim GmbH**
Frankfurt/Main, Germany
- Mercedes Benz**, Stuttgart, Germany
- Metzeler Reifen GmbH**
Munich, Germany
- Michelin Reifenwerke KGaA**
Karlsruhe, Germany
- Microsoft GmbH**
Unterschleißheim, Germany
- Mitsubishi Electric Europe B.V.**
Ratingen, Germany
- Mitsubishi MMC**, Trebur, Germany
- MOBIL OIL AG**, Hamburg, Germany
- NGK/NTK Europe GmbH**
Ratingen, Germany
- Adam Opel AG**, Rüsselsheim, Germany
- OSRAM AG**, Munich, Germany
- OMV AG**, Vienna, Austria
- Oxigen-, Carmanin-LM-Räder**,
Unterensingen, Germany
- Peugeot Deutschland GmbH**
Saarbrücken, Germany
- Pierburg GmbH**, Neuss, Germany
- Pirelli AG**, Höchst im Odenwald, Germany
- Dr. Ing. h.c. F. Porsche AG**
Stuttgart-Zuffenhausen, Germany
- Renault Nissan Deutschland AG**
Brühl, Germany
- Samsung Electronics GmbH**
Cologne, Germany
- SATA Farbspritztechnik GmbH & Co**
Kornwestheim, Germany
- SCANIA Deutschland GmbH**
Koblenz, Germany
- SEKURIT SAINT-GOBAIN**
Deutschland GmbH, Aachen, Germany
- Schäffler Automotive**, Langen, Germany
- Siemens AG**, Munich, Germany
- SKF Kugellagerfabriken GmbH**
Schweinfurt, Germany
- Snap-on/SNA Germany**,
Hohenstein-Ernstthal, Germany
- SOLO Kleinmotoren GmbH**
Sindelfingen, Germany
- SONAX GmbH**, Neuburg, Germany
- Stahlwille E. Wille**
Wuppertal, Germany
- Steyr-Daimler-Puch AG**
Graz, Austria
- Subaru Deutschland GmbH**
Friedberg, Germany
- SUN Elektrik Deutschland**
Mettmann, Germany
- Suzuki GmbH**
Oberschleißheim/Heppenheim, Germany
- Technolit GmbH**, Großlüder, Germany
- Telma Retarder Deutschland GmbH**
Ludwigsburg, Germany
- Temic Elektronik**, Nuremberg, Germany
- TOYOTA Deutschland GmbH**
Cologne, Germany
- UNIWHEELS GmbH**
Bad Dürkheim, Germany
- VARTA Autobatterien GmbH**
Hannover, Germany
- Vereinigte Motor-Verlage GmbH & Co KG**
Stuttgart, Germany
- ViewSonic Central Europe**
Willich, Germany
- Voith GmbH & Co KG**
Heidenheim, Germany
- Volkswagen AG**, Wolfsburg, Germany
- Volvo Deutschland GmbH**
Brühl, Germany
- Wabco Westinghouse GmbH**
Hannover, Germany
- Webasto GmbH**, Stockdorf, Germany
- Yamaha Motor Deutschland GmbH**
Neuss, Germany
- ZF Getriebe GmbH**
Saarbrücken, Germany
- ZF Sachs AG**, Schweinfurt, Germany
- ZF Zahnradfabrik Friedrichshafen AG**
Friedrichshafen/Schwäbisch Gmünd,
Germany

Table of contents

Abbreviations	4	3.2.1 Types of contracts	56
Contributing companies	6	3.2.2 Material defects liability, warranty and goodwill.	57
1 Motor vehicle	11	3.3 Communication	58
1.1 Evolution of the motor vehicle	11	3.3.1 Basics of communication	58
1.2 Motor vehicle classifications.	12	3.3.2 Consultations	59
1.3 Design of the motor vehicle	12	3.3.3 Customer complaints and remedial action claims.	62
1.4 The motor vehicle as technical system	13	3.4 Personnel leadership	62
1.4.1 Technical systems	13	3.5 Staff conduct.	63
1.4.2 Motor vehicle system	13	3.6 Teamwork	64
1.4.3 Subsystems in the motor vehicle	15	3.7 Order processing	65
1.4.4 Classifications of technical systems and subsystems by processing mode.	16	3.8 Data processing in a car dealership.	68
1.4.5 Using technical systems	17	3.9 Quality management in automotive service operations	71
1.5 Service and maintenance	18	4 Basics of information technology	75
1.6 Filters, composition and maintenance	20	4.1 Hardware and software.	75
1.6.1 Air filters	20	4.2 IPO concept.	75
1.6.2 Fuel filters	21	4.3 Internal data representation within the computer.	76
1.6.3 Oil filters	22	4.4 Numeric systems	76
1.6.4 Hydraulic filters	22	4.5 Structure of the computer system	77
1.6.5 Interior filters	22	4.6 Data communications	78
1.6.6 Service and maintenance	22	4.6.1 Data transfer	79
1.7 Vehicle care.	23	4.6.2 Remote data transmission	80
1.8 Fluids and lubricants, auxiliary materials	28	4.7 Data integrity assurance and data protection	81
1.8.1 Fuels.	28	5 Open- and closed-loop control technology	82
1.8.2 Fuels for spark-ignition engines.	30	5.1 Basics.	82
1.8.3 Diesel fuels	31	5.1.1 Open-loop control	82
1.8.4 Plant-based fuels	32	5.1.2 Closed-loop control	83
1.8.5 Gaseous fuels	34	5.2 Structure and components of the open-loop control system	85
1.8.6 Oils and lubricants	34	5.2.1 Signalling devices, signal types and signal conversion	85
1.8.7 Antifreeze	39	5.2.2 Control elements	87
1.8.8 Refrigerant	40	5.2.3 Actuators and drive elements.	88
1.8.9 Brake fluid	40	5.3 Control types.	89
2 Environmental protection, occupational safety	41	5.3.1 Mechanical control systems	89
2.1 Environmental protection in automotive service operations	41	5.3.2 Pneumatic and hydraulic control systems	90
2.1.1 Environmental pollution	41	5.3.3 Electric control systems.	95
2.1.2 Disposal.	41	5.3.4 Gate logic control systems	97
2.1.3 End-of-life vehicle disposal.	44	5.3.5 Process-sequence control systems	98
2.1.4 Recycling	45	6 Test technology	99
2.2 Occupational safety and accident prevention.	47	6.1 Basics of linear test technology	99
2.2.1 Basic principles of occupational safety	47	6.2 Measuring instruments.	101
2.2.2 Hazard assessment	47	6.3 Gauges	106
2.2.3 Safety measures.	50	6.4 Tolerances and fits.	107
2.2.4 Safety signs.	50	6.5 Scribing	110
2.2.5 Hazard and precautionary statements.	51	7 Production engineering	111
2.2.6 Institutions involved in occupational health and safety	52	7.1 Categorisation of manufacturing processes	111
3 Business organisation, communication	53	7.2 Creative forming.	113
3.1 Basics of business organisation.	53	7.3 Forming.	116
3.1.1 Organisation of a car dealership	53	7.3.1 Forming under bending conditions.	117
3.1.2 Aspects of the business organisation	54		
3.2 Legal principles	56		

7.3.2	Forming under combination of tensile and compressive conditions	118
7.3.3	Forming under compressive conditions	119
7.3.4	Straightening	121
7.3.5	Sheet-metal working processes	121
7.4	Separating by cutting	125
7.4.1	Basics of chip formation	125
7.4.2	Cutting and shaping by hand	125
7.4.3	Basics of cutting and shaping with machine tools	132
7.5	Separating by dividing	141
7.5.1	Cropping	141
7.5.2	Wedge-action cutting	142
7.6	Joining	143
7.6.1	Categorisation of connections	143
7.6.2	Threads	144
7.6.3	Screwed joints	145
7.6.4	Pin connections	150
7.6.5	Riveted joints	151
7.6.6	Clinching	152
7.6.7	Shaft-hub connections	153
7.6.8	Press-fit joints	154
7.6.9	Snap-in connections	154
7.6.10	Soldering	155
7.6.11	Welding	156
7.6.12	Gluing	163
7.7	Coating	164
8	Material science	166
8.1	Properties of materials	166
8.2	Categorisation of materials	170
8.3	Structure of metallic materials	171
8.4	Ferrous products	173
8.4.1	Steel	173
8.4.2	Cast-iron materials	173
8.4.3	Influence of additives on ferrous products	175
8.4.4	Designation of ferrous products	175
8.4.5	Categorisation and application of steels	177
8.4.6	Commercial forms of steel	179
8.4.7	Heat treatment of ferrous products	180
8.5	Non-ferrous metals	184
8.6	Plastics	187
8.7	Composite materials	190
9	Friction, lubrication, bearings, seals	191
9.1	Friction	191
9.2	Lubrication	192
9.3	Bearings	193
9.4	Seals	196
10	Design and operating principle of a four-stroke engine	197
10.1	Spark-ignition engine	197
10.2	Diesel engine	200
10.3	Four-stroke engine characteristics	202
10.4	Pressure-volume diagram (PV diagram)	204
10.5	Timing diagram	206
10.6	Cylinder numbering, firing orders	206
10.7	Engine performance curves	208
10.8	Stroke-to-bore ratio, power output per litre, weight-to-power ratio	209
11	Mechanical engine components	210
11.1	Crankcase, cylinder, cylinder head	210
11.1.1	Engine block	210
11.1.2	Cylinder head	213
11.1.3	Cylinder head gasket	214
11.1.4	Engine suspension	215
11.1.5	Cylinder head bolts	215
11.2	Crankshaft assembly	220
11.3	Dual-mass flywheel	232
11.4	Engine lubricating systems	233
11.5	Engine cooling systems	239
11.5.1	Types of cooling	239
11.5.2	Air cooling	240
11.5.3	Liquid cooling	240
11.5.4	Pump-cooling components	241
11.5.5	Map-controlled cooling systems	246
11.5.6	Map-cooling components	246
11.6	Engine timing gear	248
11.7	Charge optimisation	254
12	Mixture formation	270
12.1	Fuel supply systems in spark-ignition engines	270
12.2	Mixture formation in spark-ignition engines	275
12.3	Carburettor	278
12.4	Petrol injection	279
12.4.1	Basic principles of petrol injection	279
12.4.2	Design and function of electronic petrol injection	281
12.4.3	Operating data acquisition	282
12.4.4	Single-point injection	288
12.4.5	LH-Motronic	292
12.4.6	ME-Motronic	298
12.4.7	Petrol direct injection	302
12.5	Mixture formation in diesel engines	310
12.5.1	Mixture distribution/lambda values in diesel engines	310
12.5.2	Combustion process in a diesel engine	311
12.5.3	Pre-injection, main injection and post-injection	311
12.5.4	Combustion process	312
12.5.5	Inlet port control	313
12.5.6	Diesel injection process	313
12.6	Auxiliary starting assistance systems	314
12.6.1	Sheathed-element glow plugs	314
12.6.2	Flange heater	316
12.7	Injection systems for passenger car diesel engines	317
12.7.1	Electronic diesel control (EDC)	317
12.7.2	Common rail systems	319
12.7.3	Common rail systems with piezo injectors	326
12.7.4	Unit-injector system	329
12.7.5	Electronically controlled axial-piston distributor injection pump (VE-EDC)	331

12.7.6 Radial-piston distributor injection pump (VP44)	333	17.1.2 Partially self-supporting construction.	454
12.8 Injection nozzles	335	17.1.3 Self-supporting construction	454
13 Pollutant reduction	336	17.1.4 Materials in body making	455
13.1 Exhaust system	336	17.1.5 Safety in vehicle manufacturing	457
13.2 Pollutant reduction in a spark-ignition engine.	339	17.1.6 Damage assessment and measurement	464
13.2.1 Exhaust gas composition.	339	17.1.7 Accident repairs to self-supporting bodies.	468
13.2.2 Procedures for reducing pollutants	341	17.2 Corrosion protection on motor vehicles.	473
13.2.3 Diagnostics and maintenance (EI).	347	17.3 Vehicle paintwork	474
13.2.4 European On-Board Diagnostics (EOBD)	348	18 Chassis	478
13.3 Pollutant reduction in a diesel engine	352	18.1 Driving dynamics	478
14 Two-stroke spark-ignition engine, rotary engine	358	18.2 Basic principles of steering	480
14.1 Two-stroke engine	358	18.3 Steering gear	481
14.2 Rotary engine	365	18.4 Power assisted steering systems	481
15 Alternative drive concepts	367	18.4.1 Hydraulic rack-and-pinion steering.	481
15.1 Alternative sources of energy	367	18.4.2 Electro-hydraulic power steering (Servotronic)	482
15.2 Natural gas drives.	367	18.4.3 Electric power steering (Servoelectric).	483
15.3 LPG drive systems	369	18.4.4 Superimposed steering systems	485
15.4 Hybrid drives	371	18.5 Wheel adjustments.	489
15.5 Electric vehicles	392	18.6 Wheel alignment	492
15.6 Drives with fuel cells.	393	18.7 Wheel suspension systems.	496
15.7 Internal combustion engines with hydrogen operation	395	18.8 Suspension	501
15.8 Combustion engines with vegetable oil operation	395	18.8.1 Function of the suspension	501
16 Drivetrain	396	18.8.2 Operating principle of the suspension.	501
16.1 Drive types	396	18.8.3 Types of springs	503
16.2 Clutch	398	18.8.4 Vibration dampers	507
16.2.1 Friction clutch	398	18.8.5 Active Body Control (ABC).	513
16.2.2 Double-disc clutch	405	18.9 Wheels and tyres.	516
16.2.3 Multi-plate clutch	405	18.9.1 Wheel/tyre combination	516
16.3 Automatic clutch systems (ACS) with single-disc friction clutches	406	18.9.2 Wheels	516
16.4 Automatic clutch systems with twin clutches	407	18.9.3 Wheel mountings	518
16.5 Variable-speed gearbox.	411	18.9.4 Valves.	519
16.6 Manual variable-speed gearbox	412	18.9.5 Tyres.	520
16.7 Automatic gearbox.	417	18.9.6 Tyre-related forces	525
16.7.1 Automated manual gearbox	417	18.9.7 Tyre pressure monitoring systems.	527
16.7.2 Stepped automatic gearbox with hydrodynamic converter	421	18.10 Brakes	529
16.7.3 Electrohydraulic transmission control	427	18.10.1 Braking	531
16.7.4 Adaptive transmission control	434	18.10.2 Hydraulic brake	531
16.7.5 Continuously variable automatic transmission with pushbelt or link chain	435	18.10.3 Brake circuit configuration.	532
16.8 Propeller shafts, drive shafts, joints	437	18.10.4 Master cylinder	532
16.9 Final drive	440	18.10.5 Drum brake	534
16.10 Differential	443	18.10.6 Disc brake.	536
16.11 Differential locks	444	18.10.7 Brake pads	539
16.12 All-wheel drive	449	18.10.8 Parking brake systems	539
17 Vehicle body	454	18.10.9 Diagnostics and maintenance of the hydraulic brake system	540
17.1 Vehicle body/bodywork	454	18.10.10 Power-assisted brake	542
17.1.1 Separate construction	454	18.10.11 Brake force distribution	543
		18.10.12 Mechanically operated brake	544
		18.10.13 Basics of the electronic chassis control systems.	545
		18.10.14 Antilock braking system (ABS)	546
		18.10.15 Traction Control System (TCS)	551
		18.10.16 Vehicle Dynamics Control (VDC).	552
		18.10.17 Sensotronic brake control (SBC).	554

18.10.18	Additional brake functions	554	20.3.2	Luxury seats	704
18.10.19	Brake assist system (BAS)	555	20.3.3	Electronic windscreen wiper control	705
18.10.20	Emergency Brake Assist (EBA), Active Brake Assist (ABA)	555	20.3.4	Electrically adjustable exterior mirrors	705
19	Electrical engineering	556	20.4	Advanced driver assistance systems	706
19.1	General principles of electrical engineering	556	20.4.1	Cruise control system	706
19.1.1	Voltage	557	20.4.2	Adaptive cruise control (ACC)	706
19.1.2	Electrical current	557	20.4.3	Park distance control (PDC)	708
19.1.3	Electrical resistance	559	20.4.4	Parking assistance (Park Assist)	708
19.1.4	Ohm's Law	561	20.4.5	Camera-assisted parking	709
19.1.5	Power, work, efficiency	561	20.4.6	Lane change assist (lane change warning, blind spot assist)	709
19.1.6	Resistor circuits	562	20.4.7	Lane departure warning system (Lane Keeping Assist, Lane Assist)	710
19.1.7	Measurements in electrical circuits	563	20.5	Infotainment systems	710
19.1.8	Properties of electrical current	571	20.5.1	Operating and travel data display	710
19.1.9	Protection against the hazards of electrical current	572	20.5.2	Navigation systems	711
19.1.10	Voltage generation	574	20.5.3	Mobile phone cradle with linked hands-free system	712
19.1.11	Alternating voltage and alternating current	576	21	Motorcycle technology	713
19.1.12	Three-phase AC voltage and three-phase current	577	21.1	Types of motorcycle	713
19.1.13	Magnetism	577	21.2	Motorcycle engines	716
19.1.14	Self-induction	579	21.3	Exhaust system	716
19.1.15	Capacitor	580	21.4	Mixture formation	717
19.1.16	Electrochemistry	580	21.5	Engine cooling	718
19.1.17	Electronic components	582	21.6	Engine lubrication	718
19.2	Applications of electrical engineering	593	21.7	Clutch	719
19.2.1	Wiring diagrams	593	21.8	Drivetrain	720
19.2.2	Additional information and labelling in circuit diagrams	595	21.9	Electrical system	722
19.2.3	Using current diagrams	596	21.10	Riding dynamics	725
19.2.4	Overall circuit diagram of a vehicle's standard equipment	597	21.11	Motorcycle frames	726
19.2.5	Signal transmitters	605	21.12	Wheel location, suspension and damping	727
19.2.6	Relays	606	21.13	Brakes	729
19.2.7	Lighting in the motor vehicle	608	21.14	Wheels and tyres	731
19.2.8	Illuminators	609	22	Commercial vehicle technology	734
19.2.9	Power supply	617	22.1	Categorisation	734
19.2.10	Alternator	624	22.2	Commercial vehicle dimensions	735
19.2.11	Vehicle electrical system management	633	22.3	Permissible CV weights	735
19.2.12	Electric motors	635	22.4	Payload regulations	735
19.2.13	Ignition systems	642	22.5	Commercial vehicle (CV) engines	736
19.2.14	Sensors	659	22.6	Injection systems for CV diesel engines	737
19.2.15	High frequency technology	663	22.6.1	CV common rail system	738
19.2.16	Electromagnetic compatibility (EMC)	668	22.6.2	Pump-line-nozzle system (PLN)	743
19.2.17	Data transmission in motor vehicles	670	22.6.3	Auxiliary starting assistance systems	744
19.2.18	Measuring, testing, diagnostics	684	22.6.4	Reduction of harmful emissions in CV diesel engines	744
20	Comfort and convenience technology	688	22.7	Drivetrain	746
20.1	Ventilation, heating, ambient air, air conditioning	688	22.8	Chassis	749
20.2	Anti-theft systems	695	22.8.1	Suspension	749
20.2.1	Vehicle immobilisers	695	22.8.2	Wheels and tyres	752
20.2.2	Central locking system	696	22.8.3	Air brake system (brake system with external power source)	753
20.2.3	Passive access	699	22.9	Starting systems for commercial vehicles	765
20.2.4	Anti-theft alarm system (ATA)	701	23	Keyword index	769
20.3	Comfort and convenience systems	703			
20.3.1	Convertible roof actuation	703			

1 Motor vehicle

1.1 Evolution of the motor vehicle

1860 The Frenchman **Lenoir** constructs the first internal-combustion engine; this powerplant relies on city gas as its fuel source. Thermal efficiency is in the 3% range.

1867 **Otto and Langen** display an improved internal-combustion engine at the Paris International Exhibition. Its thermal efficiency is approximately 9%.

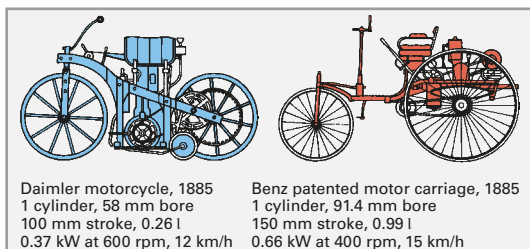

Fig. 1: Daimler motorcycle and Benz motor carriage

1876 **Otto** builds the first gas-powered engine to utilize the **four-stroke compression cycle**. At virtually the same time **Clerk** constructs the first gas-powered **two-stroke engine** in England.

1883 **Daimler** and **Maybach** develop the first high-speed **four-cycle petrol engine** using a **hot-tube ignition system**.

1885 The first **automobile** from **Benz** (patented in 1886). First **self-propelled motorcycle** from **Daimler** (Fig. 1).

1886 First **four-wheeled motor carriage** with **petrol engine** from **Daimler** (Fig. 2).

1887 **Bosch** invents the **magneto ignition**.

1889 **Dunlop** in England produces the first **pneumatic tyres**.

1893 **Maybach** invents the **spray-nozzle carburetor**. **Diesel** patents his design for a heavy oil-burning powerplant employing the self-ignition concept.

1897 **MAN** presents the first workable diesel engine.

1897 First **Electromobile** from **Lohner-Porsche** (Fig. 2).

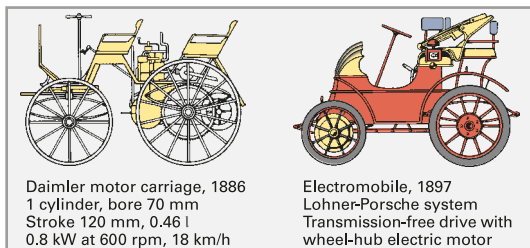

Fig. 2: Daimler motor carriage and the first Electromobile

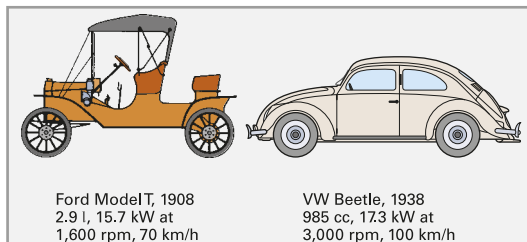

Fig. 3: Ford Model T and VW Beetle

1913 **Ford** introduces the **production line** to automotive manufacturing. Production of the **Tin Lizzy** (Model T, Fig. 3). By 1925, 9,109 were leaving the production line each day.

1916 The **Bavarian Motor Works** are founded.

1923 First **motor lorry** powered by a **diesel engine** produced by **Benz-MAN** (Fig. 4).

1936 **Daimler-Benz** inaugurates series-production of passenger cars propelled by **diesel engines**.

1938 The **VW Works** are founded in Wolfsburg.

1949 First **low-profile tyre** and first **steel-belted radial tyre** produced by **Michelin**.

1954 **NSU-Wankel** constructs the **rotary engine** (Fig. 4).

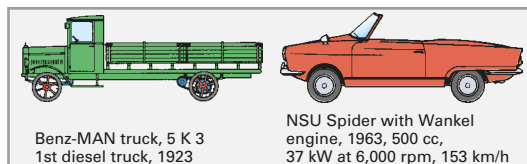

Fig. 4: Diesel-engined lorry Passenger car with Wankel rotary engine

1966 **Electronic fuel injection (D-Jetronic)** for standard production vehicles produced by **Bosch**.

1970 **Seatbelts** for driver and front passengers.

1978 Mercedes-Benz installs the first **Antilock Braking System (ABS)** in vehicles.

1984 Debut of the **airbag** and **seatbelt tensioning system**.

1985 Advent of a **catalytic converter** designed for operation in conjunction with closed-loop mixture control, intended for use with unleaded fuel.

1997 **Electronic suspension control systems (ESP)**. Toyota builds first passenger car with a **hybrid drive**. **Alfa Romeo** introduces the **common-rail direct injection (CRDI)** system for diesel engines.

As of Advanced driver assistance systems, such as **2000** parking assistance, distance warning systems, lane change assistance.

1.2 Motor vehicle classifications

Road vehicles is a category comprising all vehicles designed for road use, as opposed to operation on tracks or rails (Fig. 1).

There are basically two vehicle classes: motor vehicles and trailers. Motor vehicles always possess an integral mechanical propulsion system.

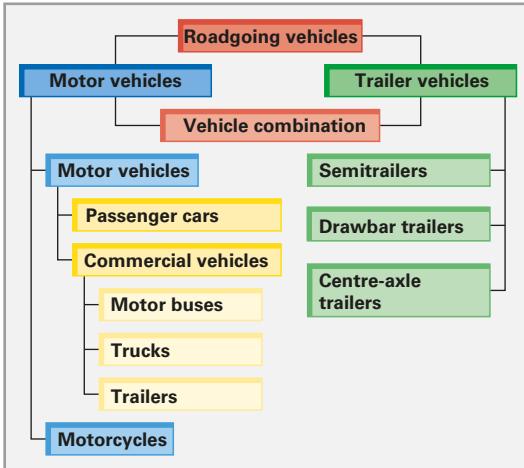

Fig. 1: Overview of road vehicles

Dual-track vehicles

Motor vehicles with more than two wheels can be found in dual-track and multiple-track versions. These include:

- **Passenger cars.** These are primarily intended for use in transporting people, as well as their luggage and other small cargo. They can also be used to pull trailers. The number of seats, including that of the driver, is restricted to nine.

- **Commercial vehicles.** These are designed to transport people and cargo and for pulling trailers. Passenger cars are not classified as commercial vehicles.

Single-track vehicles

Motorcycles are single-track vehicles with 2 wheels. A sidecar may be attached to the motorcycle, which remains classified as such provided that the unladen weight of the combination does not exceed 400 kg. A motorcycle can also be employed to pull a trailer. Single-track vehicles include:

- **Motorcycles.** These are equipped with permanent, fixed-location components (fuel tank, engine) located adjacent to the knees as well as footrests.
- **Motor scooters.** Since the operator's feet rest on a floor board, there are no fixed components at knee level on these vehicles.
- **Bicycles with auxiliary motors.** These vehicles share the same salient features as bicycles, e.g. pedals (mopeds, motorised bicycles, etc.).

1.3 Design of the motor vehicle

The motor vehicle consists of component assemblies and their individual components.

The layout of the individual assemblies and their relative positions is not governed by invariable standards. Thus, for example, the engine may be designed as an independent assembly, or it may be integrated as a subassembly within a larger powertrain unit.

One of the options described in this book is to divide the vehicle into 5 main assembly groups: engine, drivetrain, chassis, vehicle body and electrical system. The relationships between the assemblies and their constituent components are illustrated in Fig. 2.

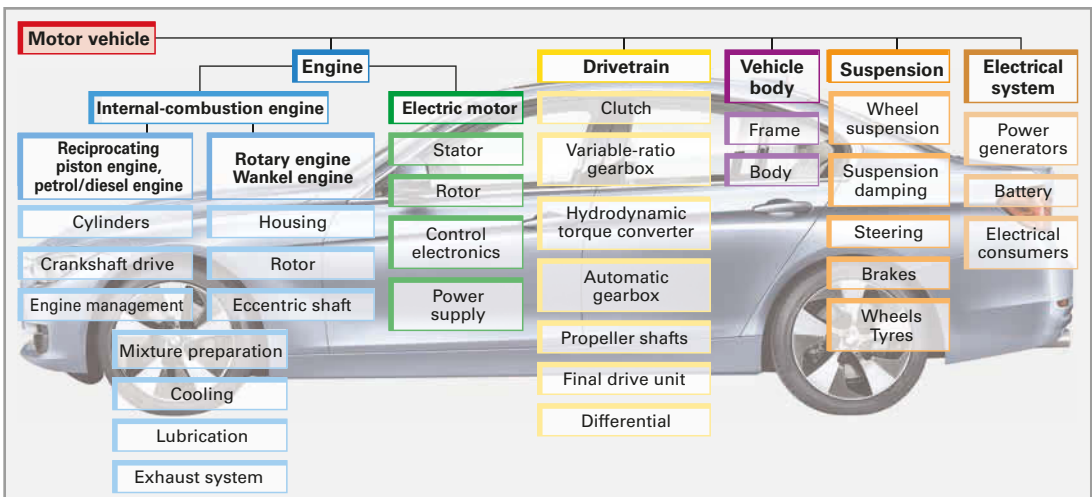

Fig. 2: Design of the motor vehicle

1.4 The motor vehicle as technical system

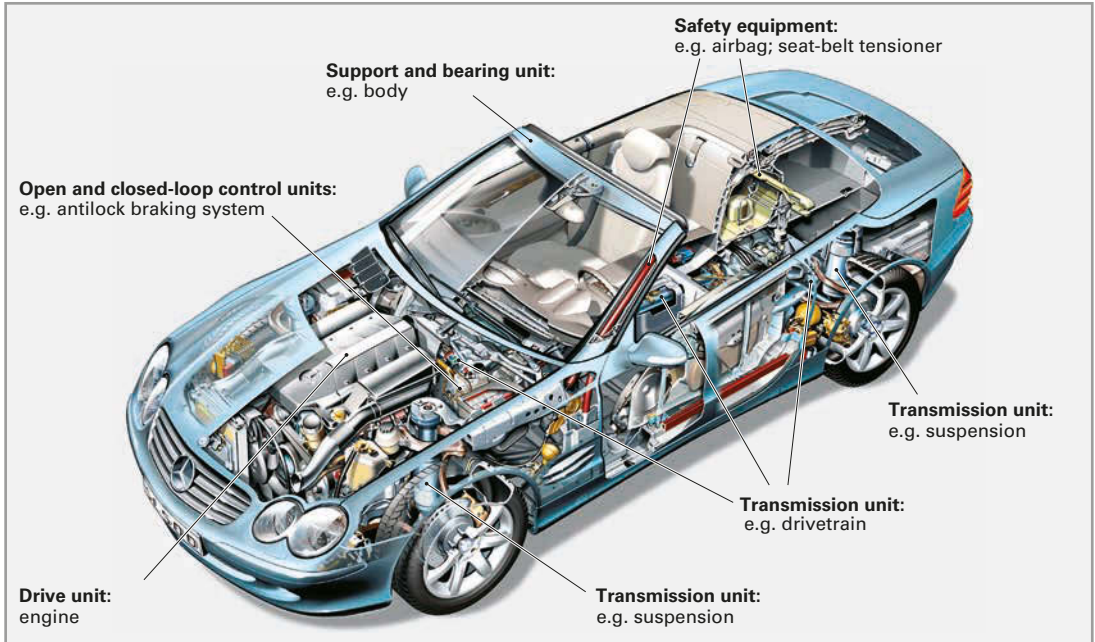

Fig. 1: The motor vehicle as a system with operational units

1.4.1 Technical systems

Every machine forms a complete technical system.

Characteristics of technical systems:

- Defined system borders delineate their limits relative to the surrounding environment.
- They possess input and output channels.
- The salient factor defining system operation is the total function, and not the individual function, which is discharged internally, within the system.

The rectangle in the figure represents the technical systems (Fig. 2).

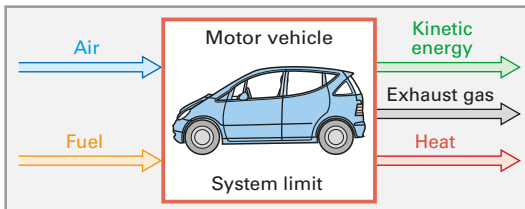

Fig. 2: Example of a basic system using a motor vehicle

Input and output variables are represented by arrows. The number of arrows varies according to the number of input and output variables.

The smaller rectangle symbolises the **system limit** (hypothetical boundary) separating each individual technical system from the other systems and/or the surrounding environment.

The distinctive, defining features of individual systems include:

- Input (input variables or parameters) entering from beyond the system limits
- Processing within the system limits
- Output (output variables or parameters) issued and relayed to destinations lying outside the limits of the system (**IPO concept**)

1.4.2 Motor vehicle system

The motor vehicle is a complex technical system in which various subsystems operate in harmony to fulfil a defined function.

The function of the passenger car is to transport people, while the function of the motor lorry, or truck, is to carry cargo.

Operational units within the motor vehicle

Systems designed to support operational processes are combined in operational units (Fig. 1). Familiarity with the processes performed in operational units such as the engine, drivetrain, etc. can enhance our

1

understanding of the complete system represented by the motor vehicle in its implications for maintenance, diagnosis and repair.

The concept is suitable for application with any technical system. Among the **operational units** that comprise the motor vehicle are the:

- Power unit
- Power-transfer assembly
- Support and load-bearing structure
- Electro-hydraulic systems (open and closed-loop control systems, etc.)
- Electrical and electronic systems (such as safety devices)

Each operational unit acts as a subsystem by assuming a specific function.

Operational unit: Power unit – engine

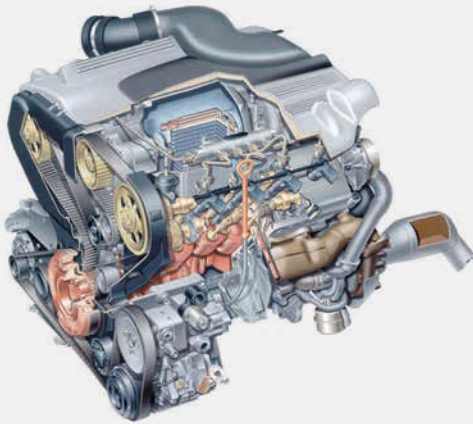

Subfunction: Provides energy for propulsion purposes

Operational unit: Power-transfer assembly, such as drivetrain

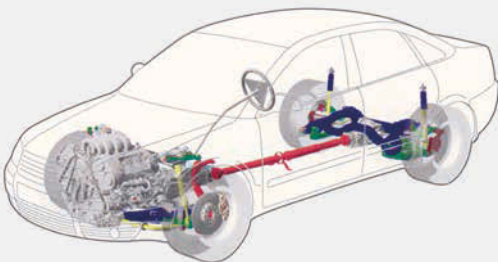

Subfunction: Relays mechanical energy from the power unit to the drive wheels

Operational unit: Vehicle structure as support structure, exemplified by body

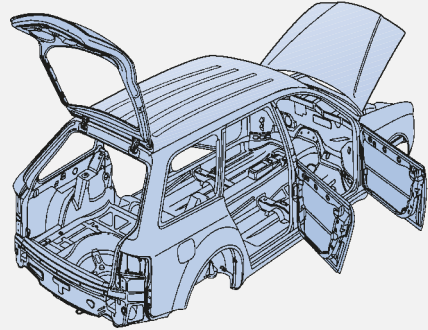

Subfunction: Support function, support for all subsystems

Operational unit: Electro-hydraulic systems (open and closed-loop control systems, such as ABS, ESP, etc.)

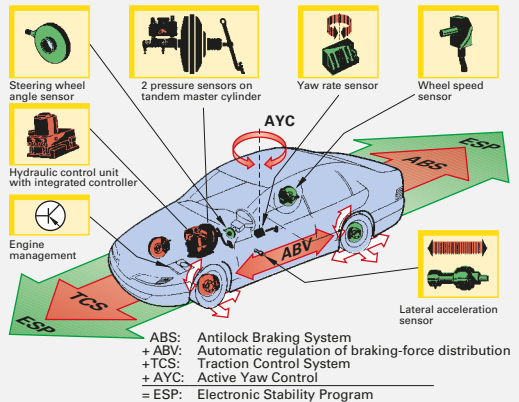

Subfunction: Active occupant protection, improvements in dynamic response

Operational unit: Electr., electron. systems (safety and security devices, such as airbags, seatbelt tensioners)

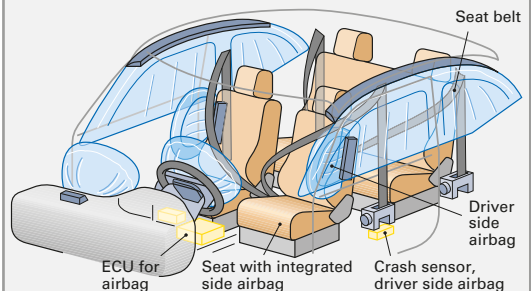

Subfunction: Passive protection for vehicle occupants

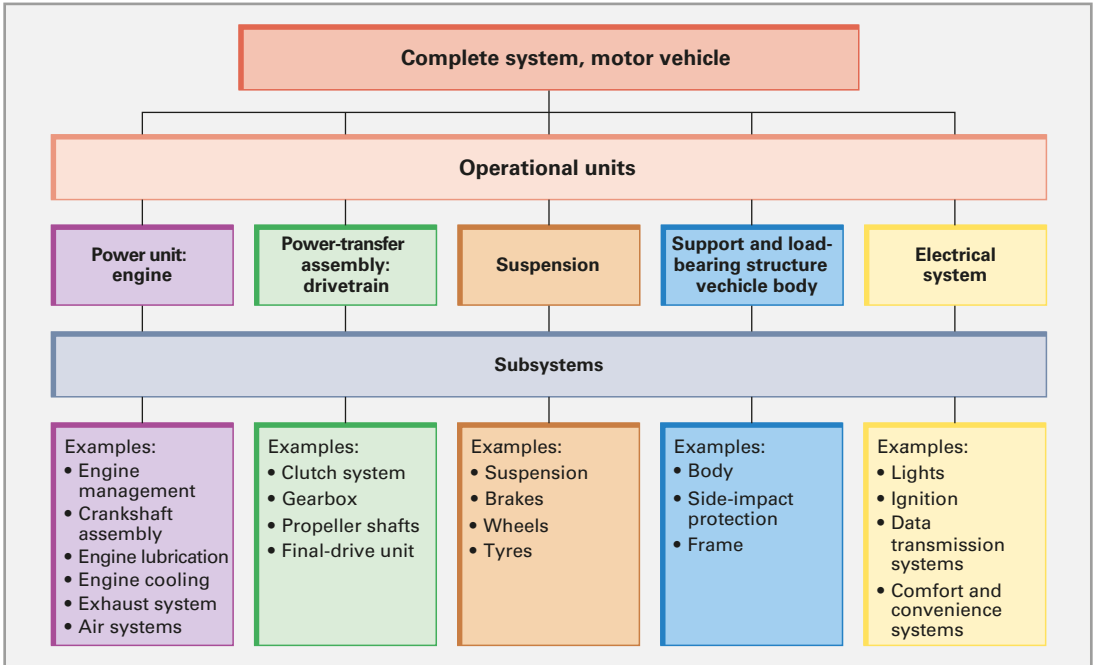

Fig. 1: The motor vehicle as composite system

Various subsystems must operate together for the motor vehicle to perform its primary functions (Fig. 1). Reducing the scale of the system’s limits shifts the focus to progressively smaller subsystems, ultimately leading to the level of the individual component.

The motor vehicle as a complete system

Defining the limits of the system to coincide with those of the overall vehicle produces boundaries in which the system’s limits border on environmental entities such as air and the road surface. On the input side, air and fuel are the only factors entering from beyond the system’s limits, while exhaust gas joins kinetic and thermal energy outside this boundary on the output side (Fig. 2, Fig. 3).

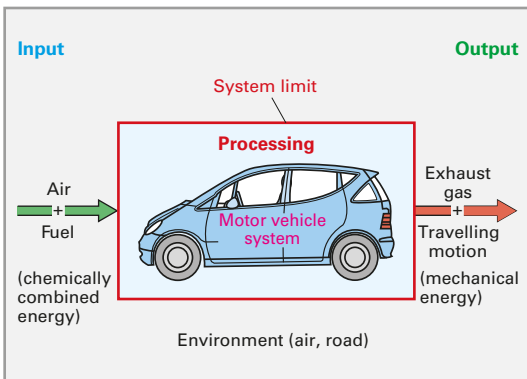

Fig. 2: System: Motor vehicle

1.4.3 Subsystems in the motor vehicle

Each subsystem is subject to the IPO concept (Fig. 3).

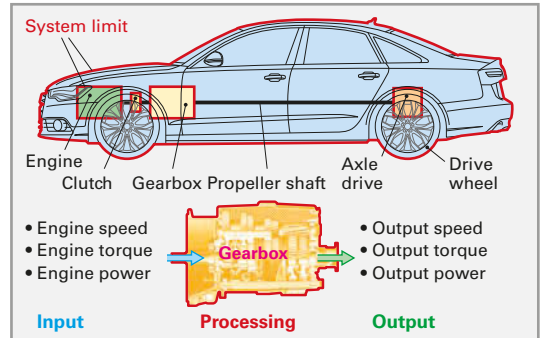

Fig. 3: Subsystem: Gearbox

Input. The factors operating on the input side of the gearbox are engine speed, engine torque and engine power.

Processing. The crankshaft’s rotational speed and the transferred torque are converted in the gearbox.

Output. The elements exiting the subsystem on the output side include output-shaft speed, output torque and output power as well as heat.

Efficiency level. The efficiency of the drivetrain is reduced by energy losses sustained within the gearbox.

The "gearbox" subsystem is connected to the drive wheels via other subsystems, such as the propeller shaft, final-drive unit, and half shafts.

1.4.4 Classifications of technical systems and subsystems by processing mode

Technical systems (**Fig. 1**) are classified according to the type of processing within overall systems:

- Material-processing systems such as the fuel-supply system
- Energy-processing systems such as the internal-combustion engine
- Information-processing systems such as the on-board computer, the steering system, etc.

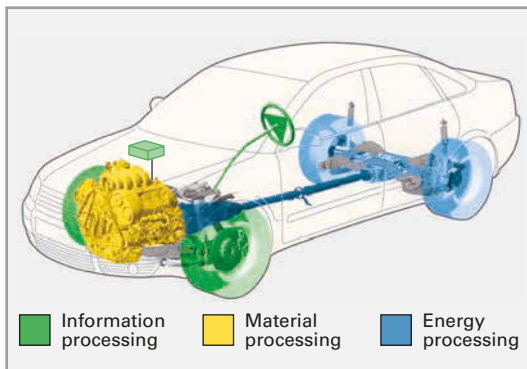

Fig. 1: Systems classified according to processing mode

Material-processing systems

Material-processing systems modify materials in their geometrical configuration (reshape) or transport them from one position to another (re-position).

Transport media and basic machinery are employed to convey substances and materials. Machine tools assume responsibility for shaping materials. To cite an example: in the material-transport process, a pump induces motion in a static fluid (gasoline in the fuel tank) in order to transport it to the fuel-injection system. For this purpose, electrical energy must be supplied to the operational machinery, such as a fuel pump, that is responsible for the process.

Overview of material-processing systems:

Machines for reshaping include machine tools such as drills, mills and lathes as well as the equipment found in foundries and stamping plants such as metal presses.

Machines for repositioning include all conveyors, transporters and machines used to transport solid materials (conveyor belts, fork lift trucks, trucks, passenger cars), liquids (pumps) and gases (fans, turbines).

Examples of material-processing systems within the motor vehicle:

- Lubrication system, in which the oil pump provides the motive power for material propulsion.
- Cooling system, in which the water pump transports a medium to support thermal transfer.

Energy-processing systems

Energy-processing systems transform energy from an external source from one form into another.

This class embraces all manner of power-generation machines, including internal-combustion engines and electric motors, steam engines and gas power plants, as well as energy units such as heat pumps, photovoltaic systems and fuel cells. In the realm of energy conversion the operative distinction is between:

- **Heat engines**, such as spark-ignition and diesel engines, and gas turbines
- **Hydraulically powered machines**, such as water turbines
- **Wind-energy devices**, such as wind-powered generators
- **Solar-energy converters**, such as photovoltaic systems
- **Fuel cells**

Within the internal-combustion engine, the fuel's chemical energy is initially converted into thermal energy before undergoing a second transformation to emerge as kinetic energy (**Fig. 2**).

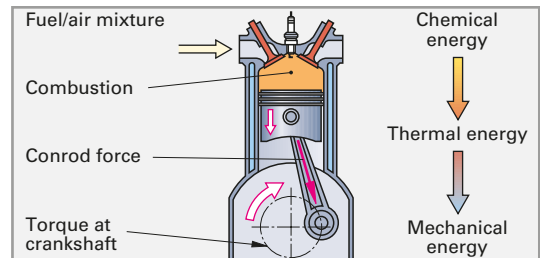

Fig. 2: Energy processing in the spark-ignition engine

This process can generate additional substances and information. Since these are of secondary importance in the operation of the energy-processing machine, they are not usually primary objects of attention.

The flow of substances and materials (entry of fuel and emission of exhaust gases) and the flow of information (fuel/air mixture, engine-speed control, steering, etc.) all assume the role of secondary functions.

Energy-processing system. The primary focus is on converting chemical energy contained in fuel into kinetic energy to propel the vehicle, with the **internal-combustion engine** serving as the energy-processing system.

Information-processing systems

These systems monitor, process and relay information and data and support communications.

Information-processing and relay systems, such as electronic control units (ECU), CAN bus controllers and diagnostic equipment (testers) assume vital significance in the maintenance of modern vehicles.

Information. Knowledge concerning conditions and processes. Examples within the vehicle include information on engine temperature, driving speed, load factor, etc. required to support vehicle operation. This information can be relayed from one electronic control unit to another. The data are registered in the form of signals.

Signals. Signals are data portrayed in physical form. Within the motor vehicle, sensors generate signals to represent parameters such as rotational speed, temperature and throttle-valve position.

Examples of information-processing systems in motor vehicles:

- **Engine control unit.** The engine-management ECU registers and processes an entire array of relevant data in order to adapt engine performance to provide ideal operation under any given conditions.
- **On-board computer.** Among its functions are to furnish the driver with information on average and current fuel consumption, estimated cruising range, average speed and outside temperature.

1.4.5 Using technical systems

Extensive familiarity with technical systems is essential for the operation and maintenance of motor vehicles. The manufacturer provides operating instructions (owner's manual) to help ensure that its vehicles operate in an environmentally responsible manner with optimal safety, security and reliability.

Operating instructions contain, among other information:

- System descriptions
- Explanations of functions and operation
- System illustrations
- Operating diagrams
- Instructions on correct operation and use of the controls
- Maintenance and service inspection schedules
- Instructions for responding to malfunctions
- Information on approved fluids, lubricants and service products, such as engine oils

- Technical data
- Emergency service addresses

Operation. Motor vehicles and machines should be operated by qualified and duly-authorised persons only.

Applicable stipulations include the following:

- The driver of a passenger car operating on public roads must be in possession of the regular driving licence required in the country of operation.
- Lift platforms and hydraulic hoists in automotive service facilities are to be operated exclusively by individuals over 18 years of age who have also received corresponding instruction in and authorisation for its use.
- The driver of a truck equipped with a crane must be in possession of a crane operator's licence.

This stipulation is intended to ensure that drivers of crane-equipped trucks have received the required training for operating lifts and hoisting equipment, and will provide the vehicle with the correct supplementary support (**Fig. 1**) while simultaneously observing all applicable accident-prevention regulations and operating the crane in a professional manner.

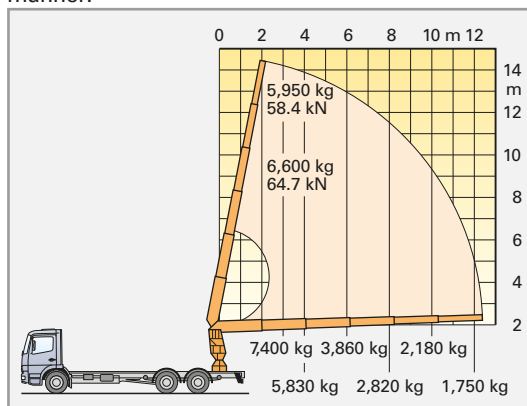

Fig. 1: Correct load distribution on a crane hoist

REVIEW QUESTIONS

- 1 What are the parameters that define a technical system?
- 2 What is the IPO concept?
- 3 What are the different operational units in the motor vehicle?
- 4 Name three subsystems in the motor vehicle, and describe the corresponding input and output variables.
- 5 What is the primary function of an energy-processing system?
- 6 What information is available in the operating instructions (vehicle owner's manual)?

1.5 Service and maintenance

Professional-quality service and maintenance, performed in accordance with the manufacturer's instructions (by the factory service organisation, etc.) are vital elements in ensuring continued vehicle safety and in maintaining the validity of the manufacturer's warranty.

Manufacturers issue **service and maintenance schedules**, spare part catalogues and **repair instructions** to guide and support these activities. This documentation is available in many forms, including menu-guided computer programs designed to run on personal computers (PCs).

Service and maintenance. Service procedures include:

- Inspections, such as test procedures
- General maintenance, comprising oil changes, lubrication and cleaning
- Remedial action, such as repairs and component replacement

Aftersales service. Vehicle manufacturers and automotive repair operations offer professional services to their customers. The services offered by these facilities include performing the prescribed preparations on new vehicles prior to delivery to the customer. Professional technicians also carry out service and maintenance work that the vehicle operator may not be able to perform. In the official service and maintenance guidelines the manufacturer defines an action catalogue intended to ensure unrestricted functionality and maintain the vehicle's value. The individual procedures are contained in the service and maintenance schedules for the specific vehicles. Service intervals can be defined according to the following criteria:

- Fixed service intervals (maintenance schedule)
- Flexible service intervals
- Demand-based service concepts

Service, maintenance and inspection operations must be performed in accordance with defined schedules. Once operations have been carried out, they should be confirmed in a service record and signed by the responsible service technician.

Maintenance schedule

This provides information on the specified service and inspection intervals by specifying (for example) a major inspection every 20,000 km or 12 months.

Service inspection schedule. This schedule defines the contents and lists the procedures included in the service inspection (**Fig. 1, Page 19**).

Flexible service intervals

Modern engine-management systems have allowed the advent of a new service concept characterised by adaptive scheduling. This concept reflects each individual vehicle's requirements based on its actual operating conditions. In addition to mileage, the system records and evaluates a variety of other factors (influencing variables) for inclusion in its calculations. A display then provides the driver with prompt notice as the inspection date approaches (**Fig. 1**). The process culminates with execution of the prescribed operations at the service facility in accordance with the service inspection schedule (**Fig. 1, Page 19**).

Oil change intervals. Two methods are available for defining oil change intervals:

- A virtual database, derived from such factors as mileage, overall fuel consumption and oil temperature curves, provides an index indicating how much the oil ages over a given period.
- The actual condition of the oil, meaning the quality and level of the oil as determined via the oil level sensor, in combination with the mileage and the registered engine load factors.

Brake pad wear. Brake pad wear is monitored electrically. When the brake pad reaches its wear limit a contact wire within the pad is perforated. The system then considers such factors as braking frequency, the duration of brake actuations and mileage in calculating the theoretically available mileage reserves, which are then reflected in the replacement intervals displayed to the driver.

Interior compartment filter wear status. Data gleaned from the outside air temperature sensor, information on heater use, use of the recirculated-air mode, vehicle speed, fan blower speed, mileage and dates all flow into calculations to determine the period remaining until the dust and pollen filter will be due for replacement.

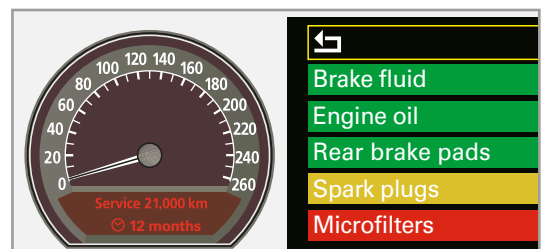

Fig. 1: Wear indicators

Spark plug replacement intervals are still based on a specific mileage, such as replacement after 100,000 km.

Replacement dates for **fluids and lubricants**, such as the coolant and brake fluid, are defined according to time, for instance, at intervals of 2 or 4 years.

Demand-based service concepts

The service date is calculated on the basis of data collected on the actual condition of wearing parts, fluids and lubricants, as well as information on the vehicle's operating conditions. When defined by this demand-based service concept, service and maintenance are carried out only when needed, for instance, when a component reaches its wear limit, or a fluid or lubricant has reached the end of its service life.

On-board computers now feature the ability to transmit coded data on the customer and the ex-

tent of the required service to the service facility. This gives the service representative time to order any required replacement parts such as brake pads and to consult with the customer in advance about a convenient service date.

Early recognition of potential problems should help avoid repairs stemming from vehicle breakdowns. Additional advantages include:

- Precisely defined dates
- Minimal waiting times
- No data loss
- Flexible service

Service inspection schedule			
Job no.: 900109	Vehicle model: Passat	Vehicle owner: Smith	
km reading/ mileage: 53,400	Vehicle age: 3	Additional work, e.g. emissions inspection:	
Servicing to be carried out			OK Not OK Rectified
Electrical system			
Front lights. Check function: Parking lights, dipped beam, main beam, fog lamps, direction indicators and hazard-warning signals			
Rear lights. Check function: Brake lights, tail lights, reversing lights, fog lamps, number plate lights, luggage compartment light, parking lights, turn indicators and hazard warning signals			
Interior and glove-compartment lights, cigarette lighter, signal horn and indicator lamps: Check function			
Self-diagnosis: Interrogate fault memories of all systems (insert printout at back of logbook wallet)			
Vehicle from the outside			
Door arresters and retaining bolts: Lubricate			
Windscreen wash/wipe system and headlight washer system: Check function and spray-nozzle setting			
Windscreen wiper blades: Check for damage, check home position; in event of rubbing wiper blades: Check contact angle			
Tyres			
Tyres: Check condition, tyre tread pattern and inflation pressure, enter tread depth			
FL _____ mm	FR _____ mm		
RL _____ mm	RR _____ mm		
Vehicle from below			
Engine oil: Drain or draw off, replace oil filters			
Engine and components in engine compartment: Visually check for leaks and damage			
V-belts, ribbed V-belts: Check condition and tension			
Gearbox, final-drive unit and joint boots: Visually check for leaks and damage			
Manual gearbox / axle drive: Check oil level			
Brake system: Visually check for leaks and damage			
Front and rear brake pads: Check thickness			
Undercoating: Visually check for damage			
Exhaust system: Visually check for leaks and damage			
Track-rod ends: Check play, mounting and sealing gaiters; axle joints: Visually check sealing gaiters for leaks and damage			
Engine compartment			
Engine oil: Check oil level (during inspection service with filter change, change oil)			
Engine and components in engine compartment (from above): Visually check for leaks and damage			
Windscreen wash/wipe system: Top up fluid			
Cooling system: Check coolant level and antifreeze; setpoint value: -25°C			
Actual value (measured value): _____ °C			
Dust and pollen filter: Replace filter element (every 12 months or every 15,000 km)			
Toothed belt for camshaft drive: Check condition and tension			
Air filter: Clean housing and replace filter element			
Fuel filter: Replace			
Power steering: Check fluid level			
Brake-fluid level (dependent on brake-pad wear): Check			
Battery: Check			
Idle speed: Check			
Headlight adjustment / documentation / final inspection			
Headlight adjustment: Check			
Service sticker: Enter date/mileage for next service (also brake-fluid renewal) on sticker and attach sticker to door pillar (B-pillar)			
Take vehicle for test drive			
Date / Signature (mechanic)			
Date / Signature (final inspection)			

Fig. 1: Service inspection schedule

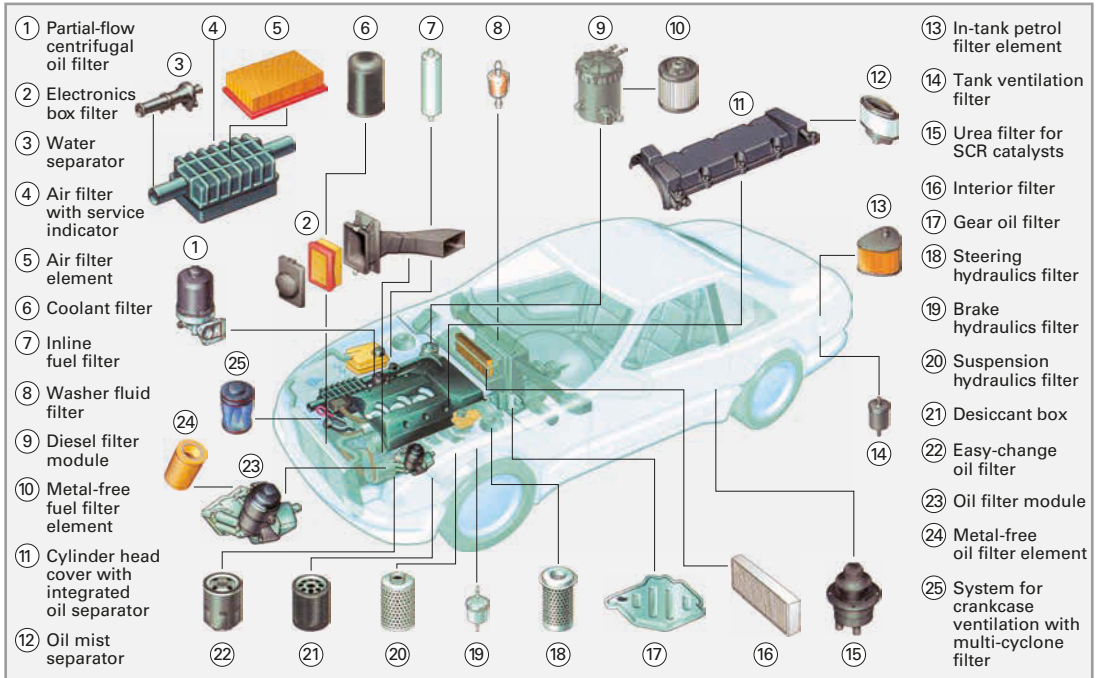

Fig. 1: Filters in modern motor vehicles

1.6 Filters, composition and maintenance

Filters installed in the motor vehicle protect the engine, other vehicle components, and the air of the vehicle's occupants against contaminants and impurities.

Motor vehicle filters (Fig. 1) can be classified according to two criteria: the **filtration concept** and the **medium** being filtered.

Filtration concepts. Solid contaminants are filtered from flowing media such as air, oil, fuel and water by:

- screen filtration, using sieve-type filter screens and fibre filters, etc.
- adhesive filtration, including wet filters
- magnetic filtration, as with magnetic separators
- centrifugal filtration, with centrifugal filters, etc.

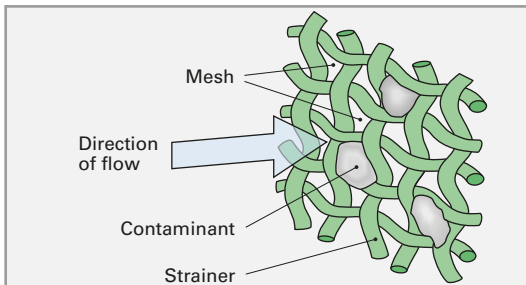

Fig. 2: Illustration of how the fine-mesh filter works

Strainers (filter screens). Filter mesh dimensions smaller than the contaminants facilitate filtration (Fig. 2).

Adhesive filters. These are usually wet air filters. Contaminants such as dust adhere to the filter surface on contact.

Magnetic filter. The filter (for instance, on the oil drain plug) attracts and retains ferromagnetic contaminants suspended in the flowing medium.

Centrifugal filter. The object medium (such as air) is placed in a state of rotation. Centrifugal force propels the contaminants onto the filter's walls, where they settle as deposits.

Filter types include:

- Air and exhaust-gas filters
- Fuel filters
- Filters for lubricating oils
- Interior filters, such as pollen, smog and ozone filters
- Hydraulic filters, for ATF, etc.

1.6.1 Air filters

The purpose of the air filter is to purify induction air while simultaneously subduing induction roar.

Airborne dust particles are minute in size (0.005 mm to 0.05 mm). The air can also contain quartz. Dust concentrations vary considerably according to vehicle operating conditions (motorway, construction site). Should it enter the oil, this dust would form an abrasive film, leading to extreme wear, especially on the cylinder walls, the pistons and the valve guides.